

Our associates will ensure the tool works properly before you leave the store. If you experience issues with the tool while completing your project, simply bring it back to the Tool Rental Center to get a replacement. If you purchase Damage Protection at the time of your rental, you are not responsible for repair costs for tools that break due to normal use.





OPERATOR'S MANUAL

Cat. No.
No de cat.
8975

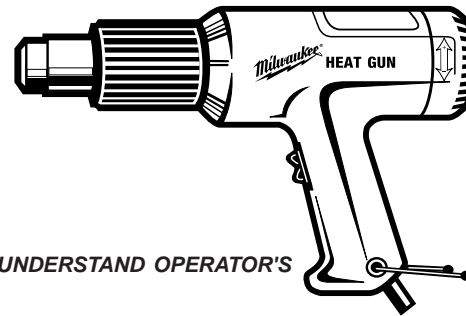

HEAVY-DUTY HEAT GUNS

TO REDUCE THE RISK OF INJURY, USER MUST READ AND UNDERSTAND OPERATOR'S MANUAL.

GENERAL POWER TOOL SAFETY WARNINGS

⚠ WARNING READ ALL SAFETY WARNINGS AND INSTRUCTIONS. Failure to follow the warnings and instructions may result in electric shock, fire and/or serious injury. **Save all warnings and instructions for future reference** The term "power tool" in the warnings refers to your mains-operated (corded) power tool or battery-operated (cordless) power tool.

WORK AREA SAFETY

- **Keep work area clean and well lit.** Cluttered or dark areas invite accidents.
- **Do not operate power tools in explosive atmospheres, such as in the presence of flammable liquids, gases or dust.** Power tools create sparks which may ignite the dust or fumes.
- **Keep children and bystanders away while operating a power tool.** Distractions can cause you to lose control.

ELECTRICAL SAFETY

- **Power tool plugs must match the outlet. Never modify the plug in any way. Do not use any adapter plugs with earthed (grounded) power tools.** Unmodified plugs and matching outlets will reduce risk of electric shock.
- **Avoid body contact with earthed or grounded surfaces such as pipes, radiators, ranges and refrigerators.** There is an increased risk of electric shock if your body is earthed or grounded.
- **Do not expose power tools to rain or wet conditions.** Water entering a power tool will increase the risk of electric shock.
- **Do not abuse the cord. Never use the cord for carrying, pulling or unplugging the power tool. Keep cord away from heat, oil, sharp edges or moving parts.** Damaged or entangled cords increase the risk of electric shock.
- **When operating a power tool outdoors, use an extension cord suitable for outdoor use.** Use of a cord suitable for outdoor use reduces the risk of electric shock.
- **If operating a power tool in a damp location is unavoidable, use a residual current device (RCD) protected supply.** Use of an RCD reduces the risk of electric shock.

PERSONAL SAFETY

- **Stay alert, watch what you are doing and use common sense when operating a power tool. Do not use a power tool while you are tired or under the influence of drugs, alcohol or medication.** A moment of inattention while operating power tools may result in serious personal injury.
- **Use personal protective equipment. Always wear eye protection.** Protective equipment such as dust mask, non-skid safety shoes, hard hat, or hearing protection used for appropriate conditions will reduce personal injuries.
- **Prevent unintentional starting. Ensure the switch is in the off-position before connecting**

- to power source and/or battery pack, picking up or carrying the tool.** Carrying power tools with your finger on the switch or energising power tools that have the switch on invites accidents.
- **Remove any adjusting key or wrench before turning the power tool on.** A wrench or a key left attached to a rotating part of the power tool may result in personal injury.
- **Do not overreach. Keep proper footing and balance at all times.** This enables better control of the power tool in unexpected situations.
- **Dress properly. Do not wear loose clothing or jewellery. Keep your hair, clothing and gloves away from moving parts.** Loose clothes, jewellery or long hair can be caught in moving parts.
- **If devices are provided for the connection of dust extraction and collection facilities, ensure these are connected and properly used.** Use of dust collection can reduce dust-related hazards.

POWER TOOL USE AND CARE

- **Do not force the power tool. Use the correct power tool for your application.** The correct power tool will do the job better and safer at the rate for which it was designed.
- **Do not use the power tool if the switch does not turn it on and off.** Any power tool that cannot be controlled with the switch is dangerous and must be repaired.
- **Disconnect the plug from the power source and/or the battery pack from the power tool before making any adjustments, changing accessories, or storing power tools.** Such preventive safety measures reduce the risk of starting the power tool accidentally.
- **Store idle power tools out of the reach of children and do not allow persons unfamiliar with the power tool or these instructions to operate the power tool.** Power tools are dangerous in the hands of untrained users.
- **Maintain power tools. Check for misalignment or binding of moving parts, breakage of parts and any other condition that may affect the power tool's operation. If damaged, have the power tool repaired before use.** Many accidents are caused by poorly maintained power tools.
- **Keep cutting tools sharp and clean.** Properly maintained cutting tools with sharp cutting edges are less likely to bind and are easier to control.
- **Use the power tool, accessories and tool bits etc., in accordance with these instructions, taking into account the working conditions**

and the work to be performed. Use of the power tool for operations different from those intended could result in a hazardous situation.

SERVICE

- **Have your power tool serviced by a qualified repair person using only identical replacement parts.** This will ensure that the safety of the power tool is maintained.

IMPORTANT SAFETY INSTRUCTIONS HEAT GUNS

READ THESE INSTRUCTIONS

- **Know your work environment.** Hidden areas such as behind walls, ceilings, floors, soffit boards and other panels may contain flammable materials that may ignite when using the heat gun in these locations. Ignition of these materials may not be readily apparent and could result in property damage and personal injury. Check these areas before applying heat. If in doubt, use an alternate method. Pausing or lingering in one spot may ignite the panel or the material behind it. Keep heat gun moving to avoid excessive temperatures.
- **Do not direct the heat gun air airflow at clothing, hair or other body parts. Do not use as a hair dryer.** Heat guns can produce 1000°F (540°C) or more of flameless heat at the nozzle. Contact with the air stream could result in personal injury.
- **Do not use near flammable liquids or in explosive atmospheres, such as in the presence of fumes, gases or dust.** The flameless heat from the heat gun may ignite the dust or fumes. Remove materials or debris that may become ignited from work area.
- **Shield materials around the heated area to prevent property damage or fire.**
- **Keep a fire extinguisher nearby.** Heat guns may ignite flammable materials left in the work area.
- **WARNING! Hot Surfaces. Always hold the heat gun by the plastic enclosure. Do not touch nozzle, accessory tips or store heat gun until the nozzle has cooled to room temperature.** The metal nozzle requires approximately 20 minutes to cool before it can be touched. Contact with the nozzle or accessory tip could result in personal injury. Place the heat gun in a clear area away from combustible materials while cooling to prevent flammable materials from igniting.
- **Do not cut off airflow by placing nozzle too close to workpiece.** Keep intake vents clean and clear of obstructions. Restricting airflow may cause the heat gun to overheat.
- **Place the heat gun on a stable, level surface when not hand held. Use the support pads or support stand.** Place cord in a position that won't cause the heat gun to tip over.
- **Do not leave the heat gun unattended while running or cooling down.** Inattention invites accidents.

- **Store indoors in a dry location.** Do not expose to rain or moisture.
- **Do not direct airflow directly on glass.** The glass may crack and could result in property damage or personal injury.
- **Maintain labels and nameplates.** These carry important information. If unreadable or missing, contact a MILWAUKEE Service facility for a free replacement.
- **WARNING** Some dust created by power sanding, sawing, grinding, drilling, and other construction activities contains chemicals known to cause cancer, birth defects or other reproductive harm. Some examples of these chemicals are:
 - lead from lead-based paint
 - crystalline silica from bricks and cement and other masonry products, and
 - arsenic and chromium from chemically-treated lumber.Your risk from these exposures varies, depending on how often you do this type of work. To reduce your exposure to these chemicals: work in a well ventilated area, and work with approved safety equipment, such as those dust masks that are specially designed to filter out microscopic particles.

IMPORTANT SAFETY INSTRUCTIONS FOR REMOVING PAINT

⚠ WARNING Use extreme care when stripping paint. Peelings, residue and vapors of paint may contain lead, which is **POISONOUS**. Pre-1977 paint may contain lead and paint made before 1950 is likely to contain lead. Hand to mouth contact with paint peelings or residue from pre-1977 paint may result in lead ingestion. Exposure to even low levels of lead can cause irreversible brain and nervous system damage. Young and unborn children are especially vulnerable to lead poisoning. **DO NOT REMOVE LEAD-BASED PAINT WITH A HEAT GUN.** Before beginning your work, determine whether the paint you are removing contains lead. A local health department or a professional who uses a paint analyzer can check the paint for lead content. **LEAD-BASED PAINT SHOULD BE REMOVED ONLY BY A PROFESSIONAL.**

PERSONS REMOVING PAINT SHOULD FOLLOW THESE GUIDELINES:

- **Work in a well ventilated area.** If possible, move the workpiece outdoors. If working indoors, open windows and place an exhaust fan in a window. Be sure the fan is moving air from inside to outside. Proper ventilation will reduce the risk of inhaling chemicals found in the fumes or dust created by using a heat gun.

- **Remove or cover any carpets, rugs, furniture, clothing, cooking utensils and air ducts** to prevent property damage from the paint peelings.
- **Place drop cloths in the work area to catch paint scrapings. Wear protective clothing** such as hats, extra work shirts and overalls. Paint scrapings may contain chemicals that are hazardous.
- **Work in one room at a time.** Remove furnishings or cover them and place in the center of the room. Seal doorways with drop cloths to seal work area from the rest of the building.
- **Children, pregnant or potentially pregnant women, and nursing mothers should not be near work area** until all work is completed and work area is cleaned thoroughly.
- **Wear a dust respirator mask or a dual filter (dust and fume) respirator mask** which has been approved by the Occupational Safety and Health Administration (OSHA), the National Institute of Safety and Health (NIOSH), or the United States Bureau of Mines. These masks and replaceable filters are readily available at major hardware stores. Be sure the mask fits. Beards and facial hair may keep masks from sealing properly. Change filters often. **DISPOSABLE PAPER MASKS ARE NOT ADEQUATE.**
- **Use caution when operating the heat gun.** Keep the heat gun moving to prevent excessive

temperatures. Excessive heat can cause paint and other materials to burn and cause fumes, which may be inhaled by the operator.

- **Keep work environment clean.** Keep food and drink away from work area. Wash hands, arms and face and rinse mouth before eating and drinking. Do not smoke, or chew gum or tobacco in the work area. Paint scrapings and dust created from removing paint may contain chemicals that are hazardous.
- **Clean up all paint scraping and dust. DO NOT SWEEP, DRY DUST OR VACUUM.** Wet mop floors. Use a wet cloth to clean all walls, sills and other surfaces where paint and dust have accumulated. Use a high phosphate detergent, trisodium phosphate (TSP), or a trisodium phosphate substitute to clean and mop the work area.
- **Dispose of paint scrapings properly.** Following each work session, place paint scrapings in a double plastic bag, close it with tape or twist ties and dispose.
- **Remove protective clothing and work shoes in the work area to avoid transferring dust to other parts of the building.** Wash work clothes separately. Wipe shoes off with a wet rag that is then washed with the work clothes. Wash hair and body thoroughly with soap and water.

SAVE THESE INSTRUCTIONS

Functional Description

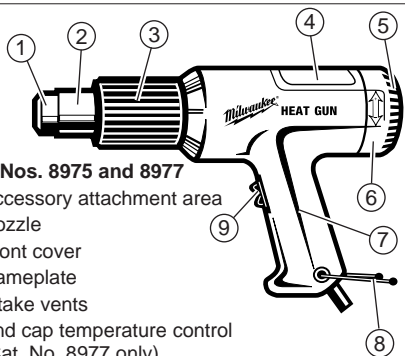

Cat. Nos. 8975 and 8977

1. Accessory attachment area
2. Nozzle
3. Front cover
4. Nameplate
5. Intake vents
6. End cap temperature control (Cat. No. 8977 only)
7. Handle
8. Support stand
9. On/off switch (On/off- high/low on 8975)

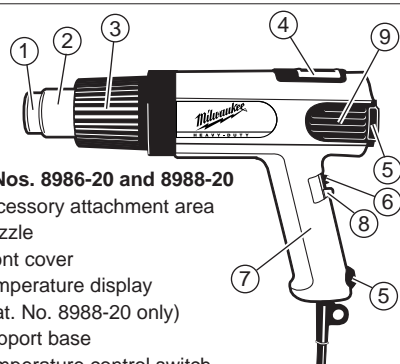

Cat. Nos. 8986-20 and 8988-20

1. Accessory attachment area
2. Nozzle
3. Front cover
4. Temperature display (Cat. No. 8988-20 only)
5. Support base
6. Temperature control switch
7. Handle
8. Airflow control switch / On/off switch
9. Intake vents

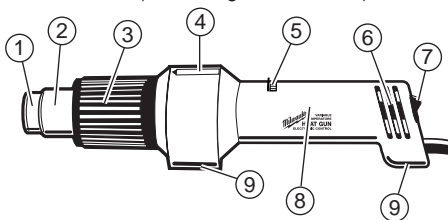

Cat. No. 8978

1. Accessory attachment area
2. Nozzle
3. Front cover
4. Nameplate
5. Heat adjustment knob
6. Intake vents
7. On/off switch
8. Handle
9. Support base

GROUNDING

WARNING Improperly connecting the grounding wire can result in the risk of electric shock. Check with a qualified electrician if you are in doubt as to whether the outlet is properly grounded. Do not modify the plug provided with the tool. Never remove the grounding prong from the plug. Do not use the tool if the cord or plug is damaged. If damaged, have it repaired by a MILWAUKEE service facility before use. If the plug will not fit the outlet, have a proper outlet installed by a qualified electrician.

Grounded Tools: Tools with Three Prong Plugs

Tools marked "Grounding Required" have a three wire cord and three prong grounding plug. The plug must be connected to a properly grounded outlet (See Figure A). If the tool should electrically malfunction or break down, grounding provides a low resistance path to carry electricity away from the user, reducing the risk of electric shock.

The grounding prong in the plug is connected through the green wire inside the cord to the grounding system in the tool. The green wire in the cord must be the only wire connected to the tool's grounding system and must never be attached to an electrically "live" terminal.

Your tool must be plugged into an appropriate outlet, properly installed and grounded in accordance with all codes and ordinances. The plug and outlet should look like those in Figure A.

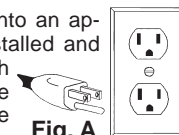

Fig. A

Double Insulated Tools: Tools with Two Prong Plugs

Tools marked "Double Insulated" do not require grounding. They have a special double insulation system which satisfies OSHA requirements and complies with the applicable standards of Underwriters Laboratories, Inc., the Canadian Standard Association and the National Electrical Code. Double Insulated tools may be used in either of the 120 volt outlets shown in Figures B and C.

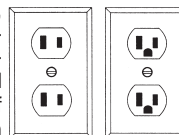

Fig. B

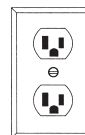

Fig. C

EXTENSION CORDS

Grounded tools require a three wire extension cord. Double insulated tools can use either a two or three wire extension cord. As the distance from the supply outlet increases, you must use a heavier gauge extension cord. Using extension cords with inadequately sized wire causes a serious drop in voltage, resulting in loss of power and possible tool damage. Refer to the table shown to determine the required minimum wire size.

The smaller the gauge number of the wire, the greater the capacity of the cord. For example, a 14 gauge cord can carry a higher current than a 16 gauge cord. When using more than one extension cord to make up the total length, be sure each cord contains at least the minimum wire size required. If you are using one extension cord for more than one tool, add the nameplate amperes and use the sum to determine the required minimum wire size.

Guidelines for Using Extension Cords

- If you are using an extension cord outdoors, be sure it is marked with the suffix "W-A" ("W" in Canada) to indicate that it is acceptable for outdoor use.
- Be sure your extension cord is properly wired and in good electrical condition. Always replace a damaged extension cord or have it repaired by a qualified person before using it.
- Protect your extension cords from sharp objects, excessive heat and damp or wet areas.

Recommended Minimum Wire Gauge for Extension Cords*

Nameplate Amperes	Extension Cord Length				
	25'	50'	75'	100'	150'
0 - 2.0	18	18	18	18	16
2.1 - 3.4	18	18	18	16	14
3.5 - 5.0	18	18	16	14	12
5.1 - 7.0	18	16	14	12	12
7.1 - 12.0	16	14	12	10	
12.1 - 16.0	14	12	10		
16.1 - 20.0	12	10			

* Based on limiting the line voltage drop to five volts at 150% of the rated amperes.

READ AND SAVE ALL INSTRUCTIONS FOR FUTURE USE.

SPECIFICATIONS

Cat. No.	Volts AC	Max. Amps	Max. Watts	Temperature	Airflow CFM*
8975	120	11.6	1400	570° F / 1000° F (300°C / 540°C)	14.8
8977	120	11.6	1400	140° F / 1040° F (60°C / 560°C)	14.8
8978	120	12.5	1500	200° F / 1100° F (93°C / 593°C)	14.8
8986-20	120	12.5	1500	90° F / 1100° F (32°C - 593°C)	7-16
8988-20	120	12.5	1500	90° F / 1100° F (32°C - 593°C)	7-16

* Cubic feet per minute

SYMBOLGY

	Double Insulated		Canadian Standards Association
	Volts Alternating Current		Underwriters Laboratories, Inc.
	Amps		Underwriters Laboratories, Inc. United States and Canada
	Watts		

ASSEMBLY

WARNING To reduce the risk of injury, always unplug tool before attaching or removing accessories or making adjustments. Use only specifically recommended accessories. Others may be hazardous.

Installing Reduction Nozzles

Reduction nozzles are used to intensify the application of heat in a specific area.

For reduction nozzle 49-80-0297:

1. To install the reduction nozzle to the heat gun, slide the nozzle onto the heat gun nose.
2. Adjust heat, distance and length of application as necessary.

For reduction nozzles 49-80-0305, 49-80-0306 (For use with electronic controlled heat guns 8978, 8986-20 and 8988-20 only):

1. To install the reduction nozzle to the heat gun, align the grooves on the nozzle with the grooves on the heat gun nose.
2. Slide the nozzle onto the nose.
3. Adjust heat, distance and length of application as necessary.

Installing Slit and Cutting Nozzles

The slit nozzle 49-80-0308 is used for lap welding. The cutting nozzle 49-80-0309 is used as a heated cutting edge.

NOTE: The reduction nozzle 49-80-0305 is needed as an attachment for the slit and cutting nozzles. (For use with electronic controlled heat guns 8978, 8986-20 and 8988-20 only):

1. To install the reduction nozzle to the heat gun, align the grooves on the nozzle with the grooves on the heat gun nose and slide the nozzle onto the nose.
2. Slide the slit or cutting nozzle onto the reduction nozzle.
3. Adjust heat, distance and length of application as necessary.

WARNING To reduce the risk of injury, do not remove accessory tips until tool has cooled to room temperature.

Installing Air Directing Nozzles

Air directing nozzles are used to change the direction of the airflow.

For hook nozzle 49-80-0292, deflector 49-80-0293, air spreader 49-80-0294, soldering reflector nozzle 49-80-0307:

1. To install an air directing nozzle to the heat gun, slide the nozzle onto the heat gun nose.
2. Adjust heat, distance and length of application as necessary.

For air reflector Cat. No. 49-80-0307 (For use with electronic controlled heat guns 8978, 8986-20 and 8988-20 only):

1. To install the air reflector nozzle to the heat gun, align the grooves on the nozzle with the grooves on the heat gun nose.
2. Slide the nozzle onto the nose.
3. Adjust heat, distance and length of application as necessary.

OPERATION

WARNING To reduce the risk of injury, always unplug tool before attaching or removing accessories or making adjustments. Use only specifically recommended accessories. Others may be hazardous.

WARNING To reduce the risk of injury, wear safety goggles or glasses with side shields.

Using the Temperature Control Switch

Cat. No. 8975

Dual temperature control heat guns have a 3 position rocker switch. Place the switch in the center position for "Low" range or press in the lower position of the switch completely for "High" range.

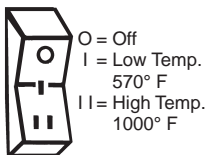

Cat. No. 8977

Variable temperature model heat guns are marked "O" for OFF and "I" for ON. Temperature is controlled by turning the end cap in the directions dictated by the arrows.

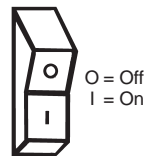

Cat. No. 8978

Electronic temperature control system heat guns allow the tool to produce a greater concentration of heat at the nozzle, allowing the use of various accessory nozzles.

The electronic control system regulates the temperature within the tool's heating element. Unlike non-electronic heat guns, MILWAUKEE's electronic heat gun will maintain the same temperature even when the air flow is decreased or restricted with the use of accessory nozzles.

Cat. No. 8978 is a variable temperature heat gun with a range between 200° F and 1100° F (93° C to 593° C). The heat adjustment knob is a dial with numbers 1 through 6 on it as shown. The lower numbers correspond to cooler temperatures and higher numbers correspond to warmer temperatures. To adjust temperature, simply turn the dial to the left or the right.

Cat. No. 8986-20 and 8988-20

These heat guns have a variable temperature control switch, which allows the user to adjust the temperature for specific applications.

The electronic temperature control system regulates the temperature within the tool's heating element. Unlike non-electronic heat guns, MILWAUKEE's electronic heat gun will maintain the same temperature even when the air flow is decreased or restricted with the use of accessory nozzles. Refer to the airflow/temperature chart for various airflow and temperature settings.

On Cat. No. 8988-20, a temperature display shows the heat gun temperature setting.

1. Slide the airflow control switch (blue switch) to Position II or III to operate the temperature control switch.
2. To adjust the temperature, slide the temperature control switch (red switch) to the desired position.

When the temperature control switch is set to the desired position on the 8988-20, the temperature for that position will show on the temperature display. After 3 seconds, the temperature display will show the heat gun's actual temperature. The temperature display will continue to show the actual temperature as the heat gun adjusts to the desired temperature set by the temperature control switch position.

Airflow/Temperature Settings (8986-20 & 8988-20)

Airflow Control Switch Setting	Airflow Fan Speed	Minimum Temp. Setting	Maximum Temp. Setting	Air Flow at Maximum Temp. Setting
Position I	High	90°F	90°F	7 CFM*
Position II	Low	90°F	1100°F	8.8 CFM
Position III	High	90°F	1100°F	16 CFM

* Cubic feet per minute

Using the Airflow Control Switch

(Cat. No. 8986-20 & 8988-20)

Cat. No. 8986-20 & 8988-20 have three airflow settings: high without heat, low with heat and high with heat. Refer to the airflow/temperature chart for various airflow and temperature settings.

1. For high airflow without heat, slide the airflow control switch (blue switch) to Position I.

NOTE: The temperature control switch (red switch) will not operate in this position.

2. For low airflow with heat, slide the airflow control switch (blue switch) to Position II. The temperature may be adjusted from 90°F to 1100°F using the temperature control switch (red switch). The airflow will automatically increase as the temperature increases.
3. For high airflow with heat, slide the airflow control switch (blue switch) to Position III. The temperature may be adjusted from 90°F to 1100°F using the temperature control switch (red switch). The airflow will automatically increase as the temperature increases.
4. To turn the heat gun off, slide the airflow control switch (blue switch) to Position 0.

Selecting Temperature

The proper amount of heat for each application depends on the temperature range selected, distance between the nozzle and workpiece, and the length of time heat is applied. Experiment with scrap materials and start with lowest temperature range. Be cautious when working until the proper combination of heat, distance and time of application has been obtained. Use a back and forth motion when applying heat unless concentrated heat is desirable.

Support Stand (Cat. Nos. 8975 and 8977)

Cat. Nos. 8975 and 8977 have a support stand, which allows you to position the heat gun upright on a workbench, leaving both hands free for your application. When using Cat. Nos. 8975 and 8977 on a workbench, always place tool on a flat surface and snap the support stand into the notched position. Place the cord so the heat gun won't tip. The rear vent openings are designed to allow air flow even when the tool is resting on the end cap, but it is important not to cover the vents with foreign materials such as clothing or rags. Cat. No. 8978 has a flat bottom surface that acts as a support stand. Rest the tool on the flat surface, making sure to place the cord so the heat gun won't tip.

APPLICATIONS

⚠ WARNING To reduce the risk of heat damage and personal injury, shield combustible materials and areas adjacent to workpiece. Protect yourself from hot paint scrapings and dust.

Removing Paint

Read safety instructions for removing paint before proceeding with paint removal.

1. Begin work with low temperature setting.
2. Place nozzle approximately 1" away from work surface.
3. Pass nozzle back and forth over a small area of workpiece.
4. Gradually increase heat until paint starts to blister, then remove heat.
5. Remove paint using a sharp-edged putty knife.

Creating Bends

Both variable temperature and dual temperature heat guns are ideal for creating bends in plexiglass that is used for guards and fixtures.

1. To form a bend, use either a low or high temperature setting. When using a low temperature, hold the heat gun close to the workpiece and pass the nozzle back and forth slowly. When using a high temperature, hold the heat gun further away from the workpiece and pass the nozzle back and forth rapidly.
2. Pass the nozzle over entire length of the surface to be bent. Applying heat to only part of the surface will make bending uneven.

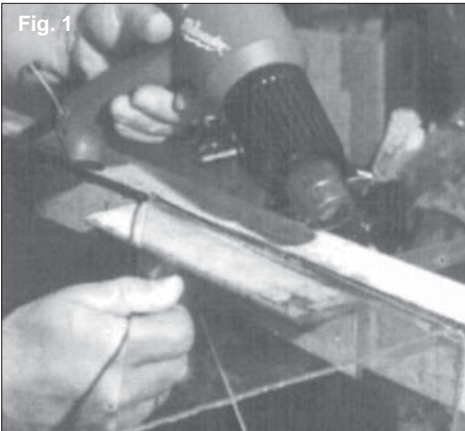

Cutting Styrofoam

1. To attach the styrofoam cutting nozzle, first attach reduction nozzle Cat. No. 49-80-0305 to the heat gun (See "Installing Reduction Nozzles"). Attach the styrofoam nozzle to the reduction nozzle.
2. To cut styrofoam, use a low to medium temperature setting and apply heat to workpiece in desired pattern. The nozzle will make straight or curved cuts and will cut holes or recesses.

NOTE: Slight smoke and odors are normal and are not harmful as long as you are working with adequate ventilation. Cut at maximum speed to avoid excess smoke development and prevent the nozzle from overheating. Read the safety instructions supplied with the material you are cutting.

Soldering

Fig. 2



1. Attach the soldering reflector nozzle or hook nozzle to the heat gun.
2. Deburr the pipe and joint using sandpaper or steel wool.
3. To solder with either lead or non-lead solder, coat the tip on both the copper pipe and the joint with flux. Then slip the joint over the pipe.
4. Slip the accessory nozzle around the joint. With the heat gun at a high temperature setting, apply heat to the joint.
5. When the flux bubbles, add solder and position heat gun so excess solder does not drip into the heat gun.

Heat Shrinking



1. Attach the soldering reflector nozzle or hook nozzle to the heat gun.
2. To heat shrink tubing, use a low temperature setting. Apply heat to the workpiece using a side to side motion until tubing has shrunk. Remove heat immediately.

MAINTENANCE

⚠ WARNING To reduce the risk of injury, always unplug your tool before performing any maintenance. Never disassemble the tool or try to do any rewiring on the tool's electrical system. Contact a MILWAUKEE service facility for ALL repairs.

Maintaining Tools

Keep your tool in good repair by adopting a regular maintenance program. Before use, examine the general condition of your tool. Inspect guards, switches, tool cord set and extension cord for damage. Check for loose screws, misalignment, binding of moving parts, improper mounting, broken parts and any other condition that may affect its safe operation. If abnormal noise or vibration occurs, turn the tool off immediately and have the problem corrected before further use. Do not use a damaged tool. Tag damaged tools "DO NOT USE" until repaired (see "Repairs").

⚠ WARNING To reduce the risk of injury, electric shock and damage to the tool, never immerse your tool in liquid or allow a liquid to flow inside the tool.

Cleaning

Clean dust and debris from vents. Keep the tool handles clean, dry and free of oil or grease. Use only mild soap and a damp cloth to clean your tool since certain cleaning agents and solvents are harmful to plastics and other insulated parts. Some of these include: gasoline, turpentine, lacquer thinner, paint thinner, chlorinated cleaning solvents, ammonia and household detergents containing ammonia. Never use flammable or combustible solvents around tools.

Repairs

If your tool is damaged, return the entire tool to the nearest service center.

Cleaning Air Filters

Cat. No. 8986-20 and 8988-20 only

The air filters on these heat guns may be removed for cleaning.

1. Unplug tool.
2. To remove the air filter, insert a flat screwdriver between the motor housing and air filter and loosen the air filter off of the back of the tool.
3. Slide the air filter off the back of the tool.
4. Remove the support pad from the air filter using the screwdriver.
5. Clean any dust or debris off the air filter using warm water and a brush.
6. To reinstall the air filter, slide the air filter onto the intake vent grooves from the back end of the tool. Allow the air filter to snap back into place.

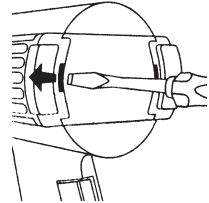

ACCESSORIES

⚠ WARNING To reduce the risk of injury, always unplug the tool before attaching or removing accessories. Use only specifically recommended accessories. Others may be hazardous.

For a complete listing of accessories refer to your MILWAUKEE Electric Tool catalog or go on-line to www.milwaukeetool.com. To obtain a catalog, contact your local distributor or a service center.